



## 16A Bipolar TRIAC Series

### Description

With high ability to withstand the shock loading of large current, this series triacs provide high dv/dt rate with strong resistance to electromagnetic interference. With high commutation performances, 3 quadrants products especially recommended for use on inductive load.

### Mechanical data

- Case: TO-220-3L
- Approx. Weight: 2.04g (0.072oz)
- Case: TO-220F-3L
- Approx. Weight: 1.767g (0.062oz)
- Case: TO-263-2L
- Approx. Weight: 1.52g (0.053oz)
- Lead free finish, RoHS compliant
- Case Material: "Green" molding compound, UL flammability classification 94V-0, "Halogen-free".

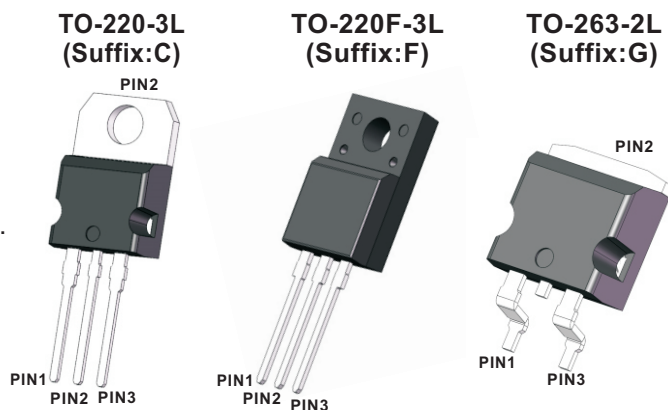

### Application Circuit

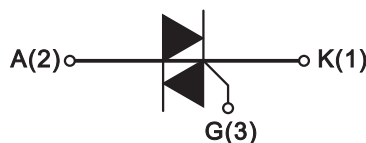

RoHS  
COMPLIANT

### ■ Absolute Maximum Ratings (Operating temperature range applies unless otherwise specified)

Parameter	Symbols	Ratings	Unit
Repetitive peak off-state voltage	V <sub>DRM</sub>	600/800/1200	V
Repetitive peak reverse voltage	V <sub>RSM</sub>	600/800/1200	V
Non repetitive surge peak Off-state voltage	V <sub>DSM</sub>	V <sub>DRM</sub> +100	V
Non repetitive peak reverse voltage	V <sub>RSM</sub>	V <sub>DSM</sub> +100	V
RMS on-state current	I <sub>T(RMS)</sub>	16	A
Non repetitive surge peak on-state current (full cycle, f=50Hz)	I <sub>TSM</sub>	160	A
I <sup>2</sup> t value for fusing (tp=10ms)	I <sup>2</sup> T	128	A <sup>2</sup> S
Peak gate current (f≥50Hz, duty cycle≤10%)	I <sub>GM</sub>	4	A
Peak gate power (f≥50Hz, duty cycle≤10%)	P <sub>GM</sub>	5	W
Average gate power dissipation(T <sub>j</sub> =125°C)	P <sub>G(AV)</sub>	1	W
Operating junction temperature range	T <sub>J</sub>	-40 to +125	°C
Storage junction temperature range	T <sub>STG</sub>	-40 to +150	°C

NOTE 1: When we parallel connect a ≤1KΩ resistor between Gate and Cathode, the T<sub>j</sub> can reach 125°C; if without this resistor, the T<sub>j</sub> only can reach 110°C.



■ Electrical Characteristics (T<sub>J</sub>=25°C Unless Otherwise Specified)

3 Quadrants

Symbols	Test Condition	Quadrant		BW	CW	SW	TW	Unit
I <sub>GT</sub>	V <sub>D</sub> =12V R <sub>L</sub> =33Ω	I - II - III	Max	50	35	10	5	mA
V <sub>GT</sub>			Max	1.3				V
V <sub>GD</sub>	V <sub>D</sub> =V <sub>DRM</sub> T <sub>J</sub> =125°C R <sub>L</sub> =3.3KΩ	I - II - III	Min	0.2				V
I <sub>L</sub>	I <sub>G</sub> =1.2 I <sub>GT</sub>	I - III	Max	70	50	30	15	mA
		II		80	60	40	20	
I <sub>H</sub>	I <sub>T</sub> =0.1A		Max	60	40	25	15	mA
dV/dt	V <sub>D</sub> =2/3 V <sub>DRM</sub> T <sub>J</sub> =125°C Gate open		Min	1000	500	200	100	V/us

4 Quadrants

Symbols	Test Condition	Quadrant		B	C	Unit
I <sub>GT</sub>	V <sub>D</sub> =12V R <sub>L</sub> =33Ω	I - II - III	Max	50	25	mA
		IV		75	50	
V <sub>GT</sub>		All		1.5		V
V <sub>GD</sub>	V <sub>D</sub> =V <sub>DRM</sub> T <sub>J</sub> =125°C R <sub>L</sub> =3.3KΩ	All	Min	0.2		V
I <sub>L</sub>	I <sub>G</sub> =1.2 I <sub>GT</sub>	I - III - IV	Max	70	50	mA
		II		100	80	
I <sub>H</sub>	I <sub>T</sub> =0.1A		Max	60	40	mA
dV/dt	V <sub>D</sub> =2/3 V <sub>DRM</sub> T <sub>J</sub> =125°C Gate open		Min	500	200	V/us

■ Static Characteristics

Symbols	Parameter		Value(Max)			Unit
			-600V	-800V	-1200V	
V <sub>TM</sub>	I <sub>T</sub> =22.5A t <sub>p</sub> =380μs	T <sub>J</sub> =25°C	1.5			V
V <sub>TO</sub>	Threshold voltage	T <sub>J</sub> =125°C	0.92			V
R <sub>d</sub>	Dynamic resistance	T <sub>J</sub> =125°C	21			mΩ
I <sub>DRM</sub>	V <sub>D</sub> =V <sub>DRM</sub> V <sub>R</sub> =V <sub>R</sub> RM	T <sub>J</sub> =25°C	5	5	10	uA
I <sub>RRM</sub>		T <sub>J</sub> =125°C	1	1	2	mA

■ Thermal Resistances

Symbols	Parameter		Value(Max)	Unit
R <sub>th(j-c)</sub>	junction to case	TO-220-3L	1.2	°C/W
		TO-220F-3L TO-263-2L	2.5	



■ Ordering Information

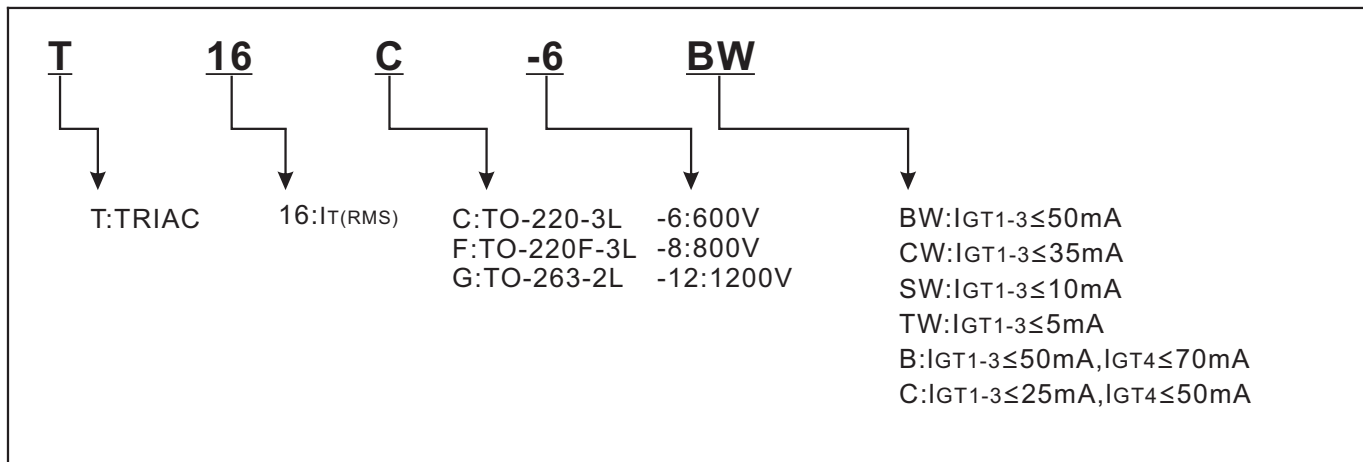



Package Outline  
Through Hole Package ; 3 leads

TO-220-3L

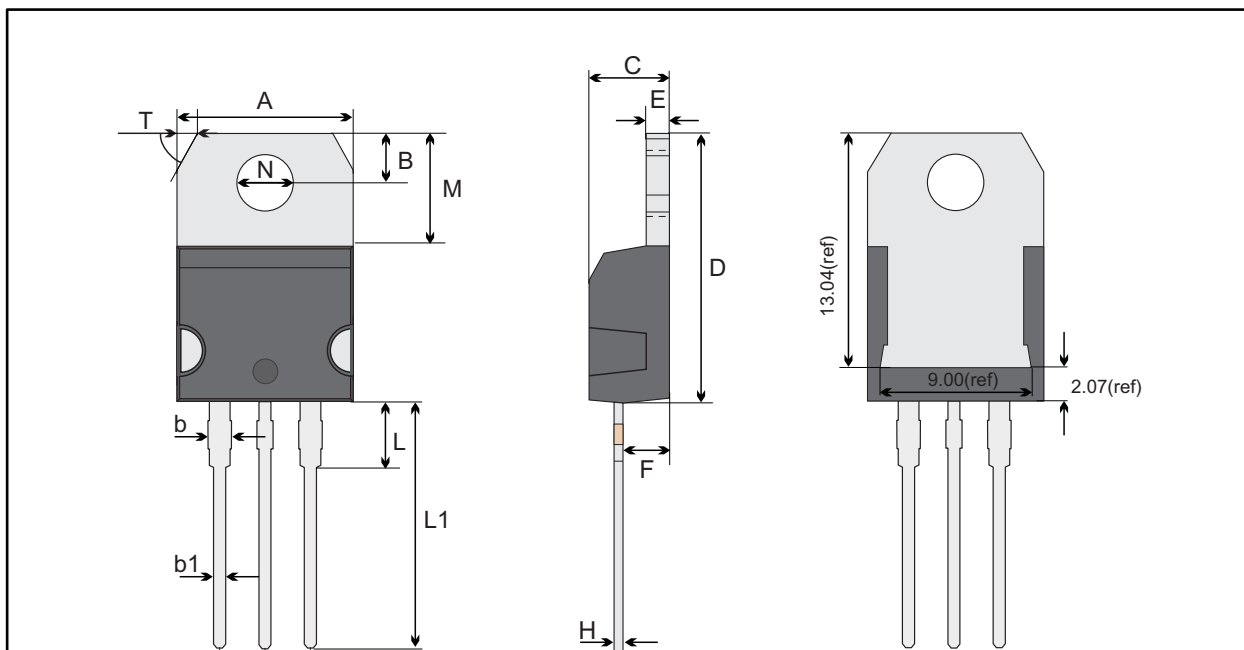

TO-220-3L mechanical data

UNIT		A	B	b	b1	C	D	E	F	G	H	L	L1	M	N	T
mm	max	10.28	2.84	1.67	0.9	4.65	15.54	1.37	2.79	2.64	0.6	3.88	13.13	6.39	3.82 typ.	1.19 58° ref.
	typ	10.18	2.74	1.47	0.8	4.45	15.34	1.27	2.59	2.54	0.5	3.68	12.93	6.19		
	min	10.08	2.64	1.27	0.7	4.25	15.14	1.17	2.39	2.44	0.4	3.48	12.73	5.99		
mil	max	405	112	66	35	183	612	54	110	104	24	153	517	252	150 typ.	47 58° ref.
	typ	401	108	58	31	175	604	50	102	100	20	145	509	244		
	min	397	104	50	28	167	596	46	94	92	16	137	501	236		

Marking Diagram

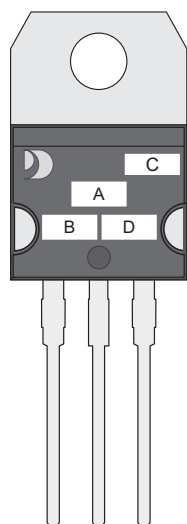

- Unmarkable Surfacea
- Marking Composition Field
- a: Ejector Pin Mark
- A: Marking Area
- B: Lot Code
- C: Additional Information
- D: Date Code (YWW)
- Y: Years(0~9)
- WW: Week



Package Outline  
Through Hole Package ; 3 leads

TO-220F-3L

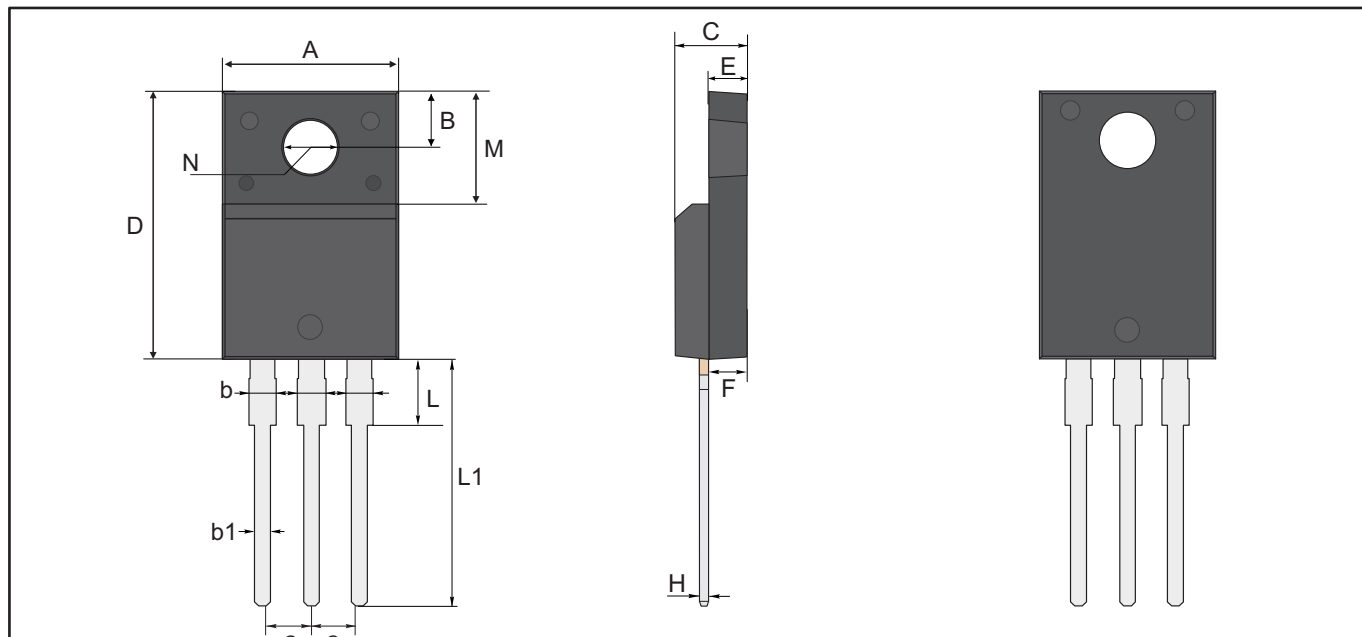

TO-220F-3L Mechanical data

UNIT		A	B	b	b1	C	D	E	F	G	H	L	L1	M	N
mm	max	10.28	3.37	1.44	0.9	4.9	16.07	2.74	2.74	2.64	0.6	2.85	13.7	6.98	3.18 typ.
	typ	10.18	3.27	1.34	0.8	4.7	15.87	2.54	2.54	2.54	0.5	2.65	13.5	6.68	
	min	10.08	3.17	1.24	0.7	4.5	15.67	2.34	2.34	2.44	0.4	2.45	13.3	6.38	
mil	max	405	133	57	35	193	633	108	108	104	24	112	539	275	125 typ.
	typ	401	129	53	31	185	625	100	100	100	20	104	531	263	
	min	397	125	49	28	177	617	92	92	96	16	96	524	251	

Marking Diagram

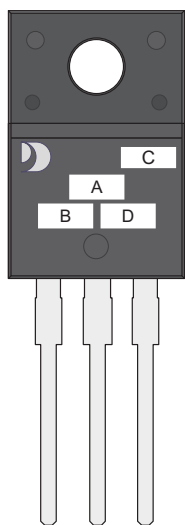

- Unmarkable Surfacea
- Marking Composition Field
- a: Ejector Pin Mark
- A: Marking Area
- B: Lot Code
- C: Additional Information
- D: Date Code (YWW)
- Y: Years(0~9)
- WW: Week



Package Outline  
Plastic surface mounted package; 2 leads

TO-263-2L

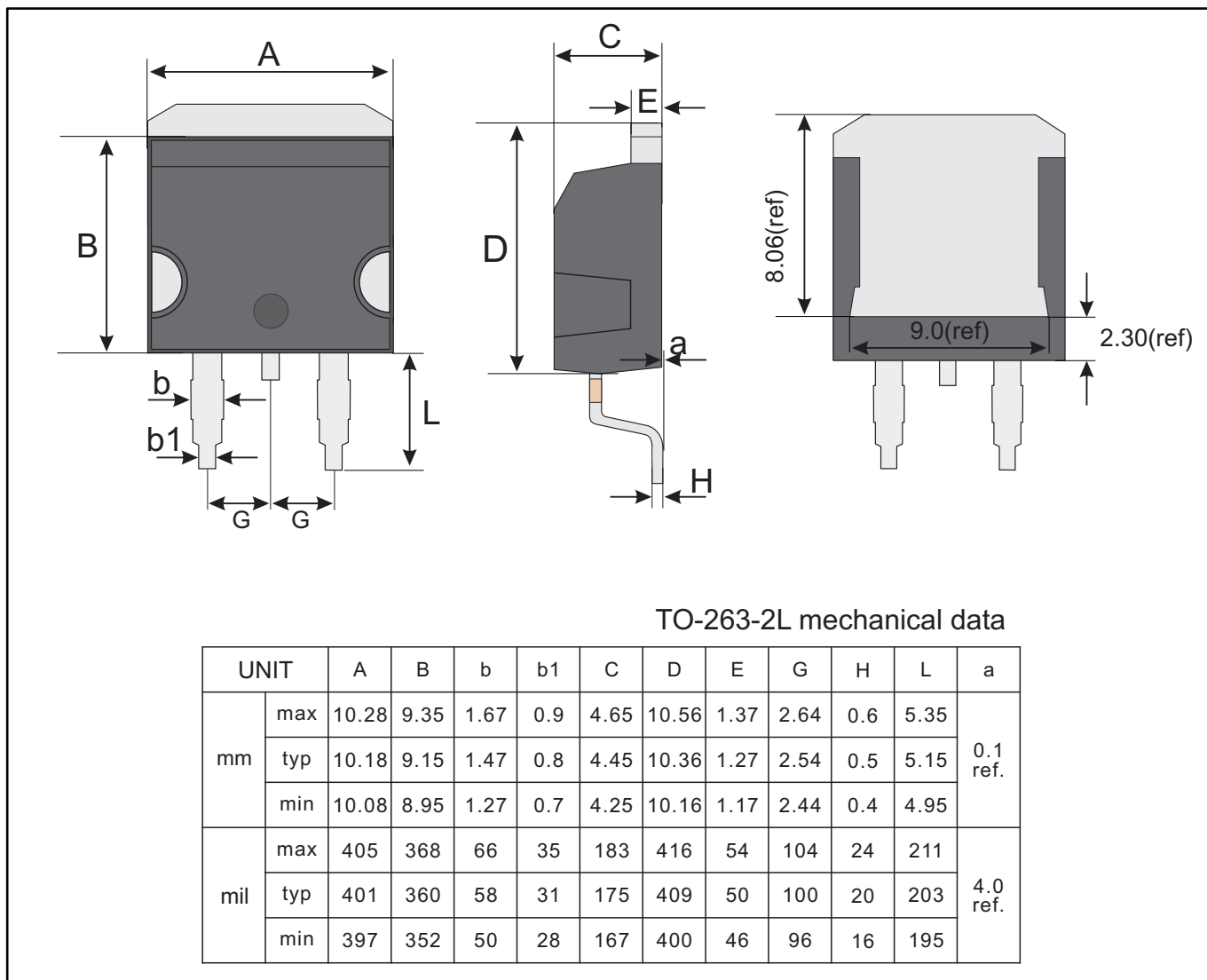

**Marking Diagram**

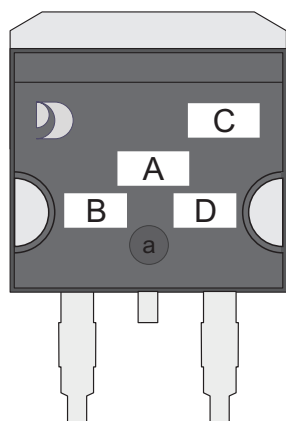

- Unmarkable Surfacea
- Marking Composition Field
- a: Ejector Pin Mark
- A: Marking Area
- B: Lot Code
- C: Additional Information
- D: Date Code (YWW)
- Y: Years(0~9)
- WW: Week



### Important Notice and Disclaimer

Jingdao Microelectronics reserves the right to make changes to this document and its products and specifications at any time without notice. Customers should obtain and confirm the latest product information and specifications before final design, purchase or use.

Jingdao Microelectronics makes no warranty, representation or guarantee regarding the suitability of its products for any particular purpose, not does Jingdao Microelectronics assume any liability for application assistance or customer product design.

Jingdao Microelectronics does not warrant or accept any liability with products which are purchased or used for any unintended or unauthorized application.

No license is granted by implication or otherwise under any intellectual property rights of Jingdao Microelectronics.

Jingdao Microelectronics products are not authorized for use as critical components in life support devices or systems without express written approval of Jingdao Microelectronics.